

# **H&S**

# **V-RAKES**

## **V-8 V-10 V-12**

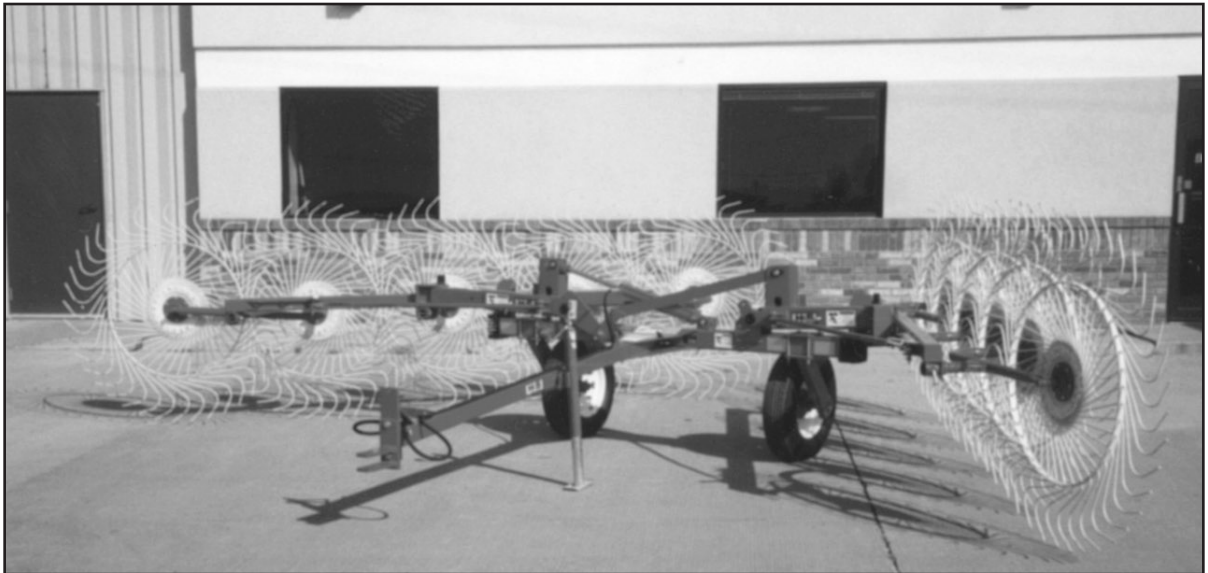

## **WARNING**

READ AND UNDERSTAND THIS MANUAL BEFORE  
OPERATING THIS EQUIPMENT.

UNSAFE OPERATION OR MAINTENANCE OF THIS EQUIPMENT CAN RESULT IN SERIOUS  
INJURY OR DEATH.

# **OPERATOR'S MANUAL**

and

# **PARTS LIST**

10-4-2008

Manufactured By

## **H&S MANUFACTURING CO., INC.**

P.O. BOX 768 • (715) 387-3414 FAX (715) 384-5463

MARSHFIELD, WISCONSIN 54449

**H&S V-RAKES  
V-8 V-10 V-12  
PARTS AND OPERATOR'S MANUAL**

**CONTENTS**

|   |                   |
|---|-------------------|
| Warranty & Warranty Registration Card . . . . .                 | 1-2               |
| Dealer Pre-Delivery & Delivery Checklist . . . . .              | 3                 |
| Be Alert Symbol . . . . .                                       | 5                 |
| Explanation of Safety Signs . . . . .                           | 6                 |
| Warning Signs . . . . .   | 7                 |
| Warning - Owner Must Read and Understand . . . . .              | 8                 |
| Operation . . . . .   | 9-10-11           |
| Adjustments . . . . .   | 12-13-14          |
| Optional Center Kicker Wheel . . . . .                          | 15                |
| Lubrication Guide . . . . .                                     | 16                |
| Decal Location & Identification . . . . .                       | 17                |
| Instructions for Ordering Parts - About Improvements . . . . .  | 18                |
| Service Notes . . . . .   | 19                |
| Figure 1 - Frame Assembly - Description . . . . .               | 20-21             |
| Figure 1 - ( <i>Continued</i> ) . . . . .                       | 22-23             |
| Figure 2 - Optional Center Kicker Wheel - Description . . . . . | 24-25             |
| Figure 3 - Hydraulic Cylinder - Description . . . . .           | 26                |
| SPECIFICATIONS . . . . .  | INSIDE BACK COVER |

**AFTER COMPLETION, DEALER SHOULD REMOVE AND RETAIN FOR RECORDS**

**H&S  
DEALER PRE-DELIVERY CHECK LIST**

After the H&S V-Rake has been completely set-up, check to be certain it is in correct running order before delivering to the customer. The following is a list of points to inspect. Check off each item as you have made the proper adjustments and found the item operating satisfactorily.

- All grease fittings have been lubricated  
See lubrication guide in this manual.
- All mechanisms are operating trouble free.
- Rake wheels touch ground in unison when lowered into raking position.  
(Rake sitting level)
- All bolts and fasteners are tight.
- All decals are in place and legible.

|                                       |                   |
|---------------------------------------|-------------------|
| (Dealer's Name)                       | Model Number      |
|                                       | Serial Number     |
| (Signature of Pre-Delivery Inspector) | (Inspection Date) |

**DEALER DELIVERY CHECK LIST**

This check list that follows is an important reminder of valuable information that should be passed on to the customer at the time this V-Rake is delivered.

Check off each item as you explain it to the customer.

This pre-delivery check list, when properly filled out and signed assures the customer that the pre-delivery service was satisfactorily performed.

- Explain to the customer that the pre-delivery inspection was made.
- Explain to the customer all the safety precautions they must exercise when operating this unit.
- Explain to customer that regular lubrication is required for proper operation and long life of machine. Show customer the lubrication section of Owner's Manual.
- Give the customer Owner's Manual and make sure he reads and understands all operating and service instructions.
- Record Serial Number on Page 18 of this Manual.
- Have customer sign a completed "Warranty Registration," and mail it promptly.

Date Delivered \_\_\_\_\_ Dealer's Name \_\_\_\_\_

By \_\_\_\_\_

\_\_\_\_\_  
Signature of Original Buyer

Note: Warranty is not valid until warranty card is completed and returned to H&S Mfg. Co., Inc.

Remove Dealers File Copy At Perforation





**BE  
ALERT!**      **YOUR SAFETY  
IS INVOLVED.**

**THIS SYMBOL IS USED THROUGHOUT THIS BOOK WHENEVER YOUR PERSONAL SAFETY IS INVOLVED. TAKE TIME TO BE CAREFUL. REMEMBER: THE CAREFUL OPERATOR IS THE BEST OPERATOR. MOST ACCIDENTS ARE CAUSED BY HUMAN ERROR. CERTAIN PRECAUTIONS MUST BE OBSERVED TO PREVENT THE POSSIBILITY OF INJURY OR DAMAGE.**

**TRACTORS**

**This operator's manual uses the term "Tractor" when identifying the power source for towing and lifting rake.**

**H&S MANUFACTURING CO. INC.**

## RECOGNIZE SAFETY INFORMATION

This is the safety-alert symbol. When you see this symbol on your machine or in this manual, be alert to the potential for personal injury.

Follow recommended precautions and safe operating practices.



## UNDERSTAND SIGNAL WORDS

A signal word—DANGER, WARNING, or CAUTION—is used with the safety-alert symbol. DANGER identifies the most serious hazards.

Safety signs with signal word DANGER or WARNING are typically near specific hazards.

General precautions are listed on CAUTION safety signs.



**WARNING**



**CAUTION**



## FOLLOW SAFETY INSTRUCTIONS

Carefully read all safety messages in this manual, and all safety signs on your machine. Follow all recommended precautions and safe operating procedures.

Keep signs in good condition. Immediately replace any missing or damaged signs.

**! WARNING**

**HELP AVOID INJURY**

- READ & UNDERSTAND THE OPERATORS MANUAL PROVIDED WITH THIS MACHINE. IF MISPLACED CALL H & S MANUFACTURING AT **715-387-3414** WITH MODEL AND SERIAL NUMBER.
- UNDERSTAND ALL SAFETY WARNINGS AND FUNCTION OF CONTROLS.
- KEEP SAFETY DEVICES IN PLACE AND WORKING.
- KEEP YOURSELF AND OTHERS WELL CLEAR OF MOVING PARTS.
- DISCONNECT ALL POWER BEFORE SERVICING OR CLEANING THIS MACHINE.
- DO NOT EXCEED 20 MPH

72203A

**! WARNING**



**STAY CLEAR OF RAKE WHEN RAISING OR LOWERING RAKE WHEELS.**

**FAILURE TO HEED THIS WARNING MAY RESULT IN PERSONAL INJURY OR DEATH.**

**KEEP CLOTHING, YOURSELF AND OTHERS WELL CLEAR.**

2700B



**! WARNING**

**STAY CLEAR OF RAKE WHEN RAISING OR LOWERING RAKE WHEELS.**

**FAILURE TO HEED THIS WARNING MAY RESULT IN PERSONAL INJURY OR DEATH.**

**KEEP CLOTHING, YOURSELF AND OTHERS WELL CLEAR.**

2700A



**! WARNING**

**INSTALL LOCKING PINS FOR SERVICE OR TRANSPORT.**

**FAILURE TO HEED THIS WARNING MAY RESULT IN PERSONAL INJURY OR DEATH.**

73100B



**! WARNING**

**INSTALL LOCKING PIN FOR SERVICE, TRANSPORT, OR WHEN RAKING WITH ONE SIDE. SEE OPERATOR'S MANUAL.**

**FAILURE TO HEED THIS WARNING MAY RESULT IN PERSONAL INJURY OR DEATH.**

73100C



**! WARNING**

**DO NOT GO NEAR LEAKS**

- High pressure oil easily punctures skin causing serious injury, gangrene or death.
- If injured, seek emergency medical help. Immediate surgery is required to remove oil.
- Do not use finger or skin to check for leaks.
- Lower load or relieve hydraulic pressure before loosening fittings.

11599

## H&S V-RAKES



# WARNING

### TO PREVENT SERIOUS INJURY OR DEATH

BEFORE YOU ATTEMPT TO OPERATE THIS EQUIPMENT, READ AND STUDY THE FOLLOWING INFORMATION. IN ADDITION, MAKE SURE THAT EVERY INDIVIDUAL WHO OPERATES OR WORKS WITH THIS EQUIPMENT, WHETHER FAMILY MEMBER OR EMPLOYEE, IS FAMILIAR WITH THESE SAFETY PRECAUTIONS.

**DO NOT ALLOW PERSONNEL OTHER THAN THE QUALIFIED OPERATOR NEAR THE MACHINE.**

**IF RAKE ARMS ARE IN THE RAISED POSITION, MAKE SURE TRANSPORT LOCK PINS (10WR4) ARE INSTALLED TO LOCK ARMS UP BEFORE CLEANING, WORKING ON, OR ADJUSTING MACHINE.**

**DO NOT** attempt to perform maintenance or repair with tractor running.

**DO NOT** step up on machine at any time.

**DO NOT** allow minors to operate or be near the machine.

Stay clear of hydraulic lines, they may be under extreme pressure or heat.

Stay clear of rake when raising or lowering main rake arm beams.

For transport and storage, always make sure that the transportation lock pins (10WR4) are positioned to lock the rake arms in the up position.

H&S Mfg. Co. always takes the operator and his safety into consideration and guards exposed moving parts for his protection. However, some areas cannot be guarded or shielded in order to assure proper operation. In addition, the operators manual and decals on the machine itself warn you of further danger and should be read and observed closely.

**Study The Above Safety Rules**

**ATTENTION - BE ALERT - YOUR SAFETY IS INVOLVED**



# OPERATION

1. Check for proper assembly and adjustment and make sure that all bolts are tightened. Securely retighten after a few hours of operation as bolts can loosen up on new machinery. Check wheel bolts upon delivery and periodically thereafter. Wheel bolts should be tightened at 95 ft./lbs. of torque.
2. Check tires and inflate to recommended pressure.
3. Attach tractor hitch (13 to 17 inches above ground) and attach rake to tractor with a hitch pin that has a safety locking device.
4. Remove weight from lift jack. Rotate jack into storage position
5. Connect hydraulic hose for raising and lowering rake arms.
6. On all rake wheels, tooth bolts must be torqued to 40 ft./lbs. to help prevent excessive tooth breakage. **Re-torque rake tooth bolts after first 100 acres. (Part No. T175) Check periodically thereafter.**

**NOTE:** Determine right or left side of your V-Rake by viewing it from the rear. If instructions or parts lists call for hardened bolts, they are identified as Grade 5 by three lines on the head.

## ADJUSTMENTS

There are two different positions to adjust the hitch on your new V-Rake. The hitch should be adjusted so the main rake beams are level, or parallel to the ground.



### **WARNING**

#### **DO NOT GO NEAR LEAKS**

- High pressure oil easily punctures skin causing serious injury, gangrene or death.
- If injured, seek emergency medical help. Immediate surgery is required to remove oil.
- Do not use finger or skin to check for leaks.
- Lower load or relieve hydraulic pressure before loosening fittings.



# OPERATION *(Continued)*

## TRANSPORT LOCKS

There are two transport locks on the V-Rake. The transport pins (10WR4) lock the rake beams into the up position for cleaning or working on the rake and for transport and storage. The pins should be in the storage position during operation.

|   |
|---|
| <b>⚠ WARNING</b>  |
|    |
| <b>STAY CLEAR OF RAKE<br/>WHEN RAISING OR LOWERING<br/>RAKE WHEELS.</b>             |
| <b>FAILURE TO HEED THIS<br/>WARNING MAY RESULT IN<br/>PERSONAL INJURY OR DEATH.</b> |
| <b>KEEP CLOTHING, YOURSELF<br/>AND OTHERS WELL CLEAR.</b>                           |

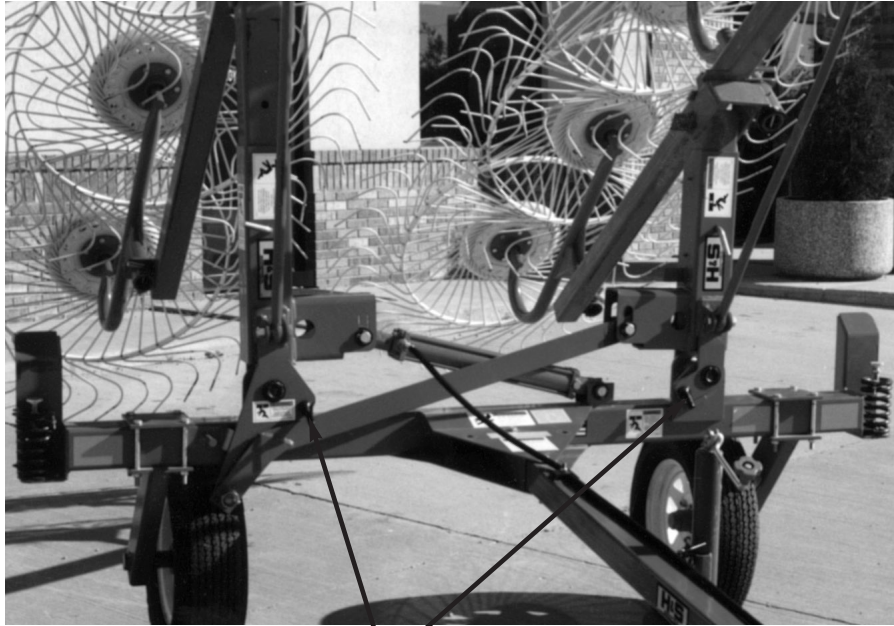

**Transport Position**

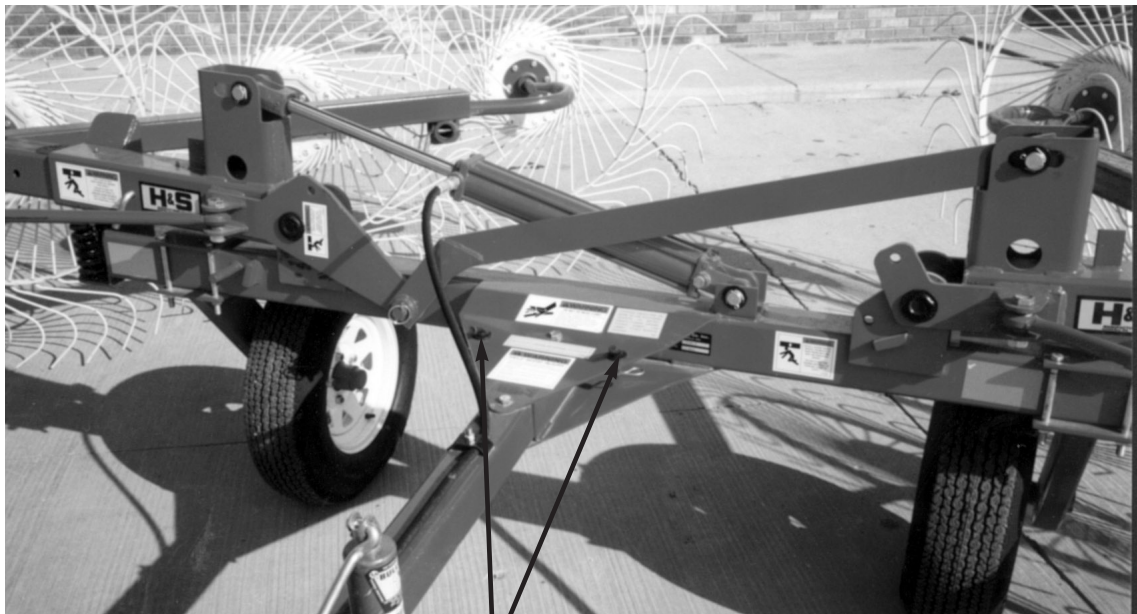

**Raking Position**

## OPERATION *(Continued)*

Raking with one side can be accomplished by locking the left rake arm in the transport position, disconnecting the lifting linkage (10WR35 or 12WR5), then putting it into the lifting linkage storage position.



Left Side Transport Position



Remove Lifting Linkage

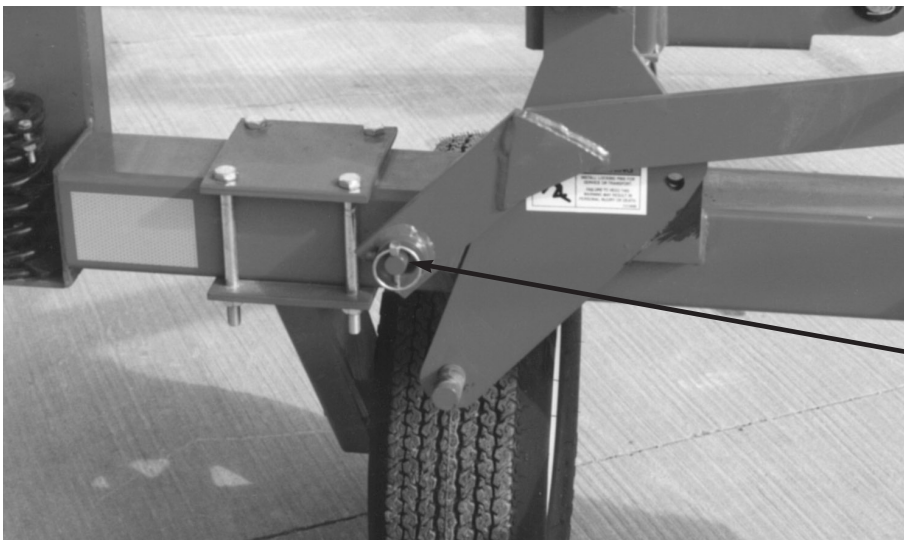

Place in Storage Position



# ADJUSTMENTS

## RAKING WIDTH

There are three rake width adjustments on each rake arm. Width on each side can be set independently. Each rake beam angle can be adjusted independently for multiple raking combinations. Fine tuning is accomplished by adjusting the threaded ball end attached to the linkage arm.



Rake Width Adjustments

|  |  |
|--|--|
|  | <p><b>⚠ WARNING</b></p> <p>STAY CLEAR OF RAKE<br/>WHEN RAISING OR LOWERING<br/>RAKE WHEELS.</p> <p>FAILURE TO HEED THIS<br/>WARNING MAY RESULT IN<br/><u>PERSONAL INJURY OR DEATH.</u></p> <p>KEEP CLOTHING, YOURSELF<br/>AND OTHERS WELL CLEAR.</p> |
|--|--|

Locking Pin (10WR14)

## WINDROW WIDTH

Remove locking pin (10WR14). Remove jack from jack storage position. Position jack mount tube on top of rake beam pin (10WR6) with jack foot in position as shown. Windrow width can now be adjusted from 4' to 6', in 6" increments on each side of the rake. After the desired windrow width has been reached, re-insert pin (10WR14) in desired hole. Remove jack, and return to storage position.



Rake Beam Pin (10WR6)

## ADJUSTMENTS *(Continued)*

### DOWN PRESSURE

Down pressure of the rake arms can be adjusted by adjusting the stop on top of the spring located at each end of the main frame. The stop should be adjusted so there is approximately 1/4 of an inch of threads showing above the jam nut. The V-Rake can be adjusted for less ground pressure by “raising” the stop.

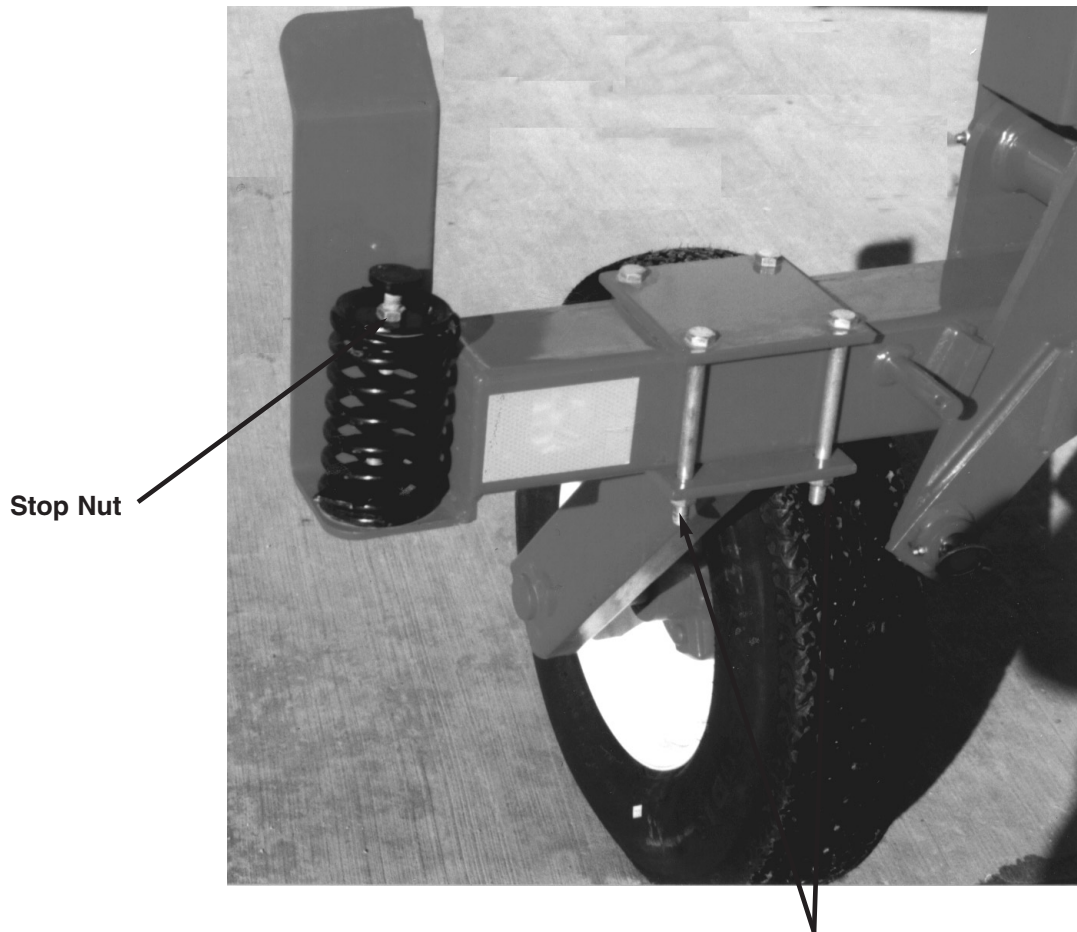

**Mounting Bolts (16SV77)**

### TREAD WIDTH ADJUSTMENT (V-12 Only)

Tread width (wheel spacing) can be adjusted by first jacking up one side of the main frame. Loosen nuts (4) on the mounting bolts (16SV77). The entire wheel assembly now can be positioned as desired. Re-tighten nuts evenly. Repeat procedure on the opposite of the main frame.

## ADJUSTMENTS *(Continued)*

### FLOTATION

The V-Rake has been designed to be operated with the hydraulic cylinder in the float position. This allows the rake beam to “float” up and down without the hydraulic cylinder restricting it’s motion. If your tractor does not have a float position, you will need the second hose option. **If rake is equipped with second hose option, it is very important transport lock pins are removed prior to attempting to lower rake arms. Failure to remove pins will result in damage to rake.**



**NOTE:** If 2 hose system is desired, remove vent plug and install hose (3/8” x 145”) (Part #10WR10) between cylinder and tractor.

## OPTIONAL CENTER KICKER WHEEL

An optional center kicker wheel is available for the V-Rake. If the hay is laying out flat, the extra wheel allows you to raise the hay laying in the center of the rake out of the stubble for easier pick-up. Attached to the right lifter arm with a cable, the center kicker wheel will raise and lower when the hydraulics are activated. The center kicker wheel may be locked in the up position when not needed.

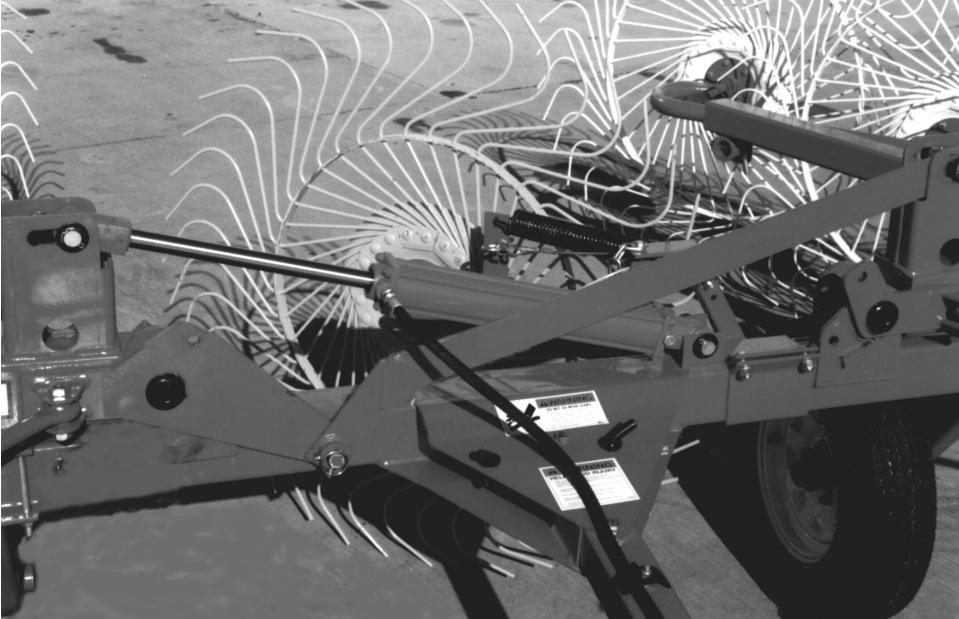

**Down  
Position**

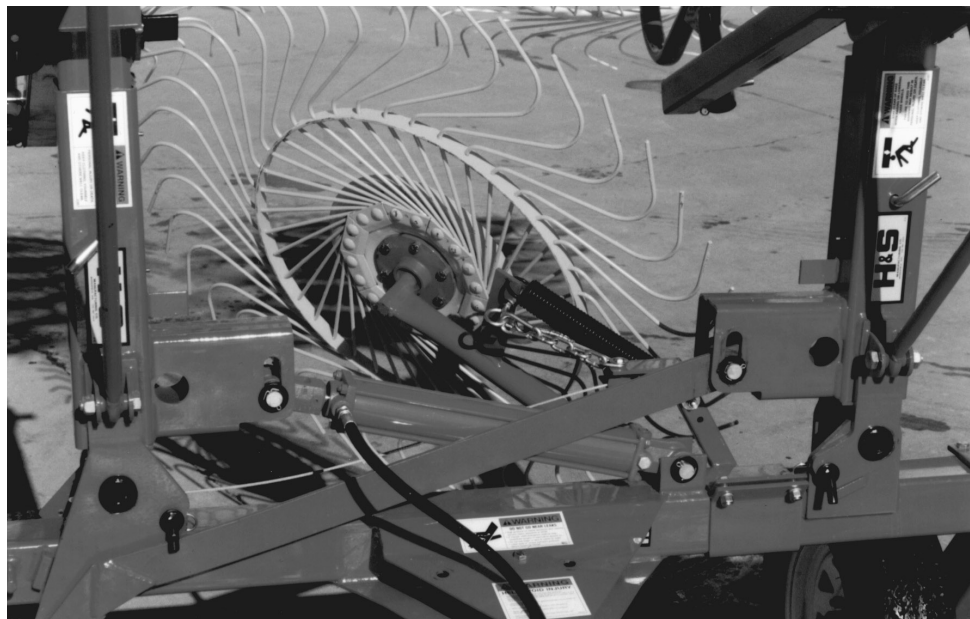

**Up  
Position**



# LUBRICATION GUIDE

## GREASE FITTINGS

There are numerous grease fittings on your V-Rake. If these are lubricated properly and often enough, it will prolong the life of your V-Rake. Grease daily during normal use and before and after storage. Use a good grade of high quality grease. Wipe off excessive grease to prevent accumulation of chaff or grit around the bearing.

## LOCATION

Listed and shown are the description of location and number of grease fittings.

- A. (2) one on each end of left side lift linkage
- B. (2) one on each pivot arm pivot point
- C. (4) two on each of the lifter arms
- D. (2) one on each horizontal pivot point at the end of the lifter arms
- E. (2) one on each vertical pivot point, rake arm mount
- F. (1) Center kicker wheel arm (if so equipped)
- G. (4) Rake Arm mount (6 on V-10 & V-12)





# DECAL LOCATION

Your H&S V-Rake was manufactured with operator safety in mind. Located on the V-Rake are various decals to aid in operation, and warn of danger or caution areas. Pay close attention to all decals.



**DO NOT REMOVE ANY OF THESE DECALS. IF DECALS ARE LOST, DAMAGED, OR IF V-RAKE IS REPAINTED, REPLACE DECALS. REMEMBER: DECALS ARE FOR YOUR PROTECTION AND INFORMATION.**

Listed below are the decals on your V-Rake. These decals may be ordered individually by part number or by ordering a complete set.

| ITEM | PART NO. | DESCRIPTION                                       |                 |        |
|------|----------|---|-----------------|--------|
| A.   | 2700A    | (2) Warning - Stay Clear of Rake                  |                 |        |
| B.   |          | (2) Amber Decal (Reflective) (4) on 12 Wheel Only |                 |        |
| C.   |          | (2) Red Decal (Reflective)                        |                 |        |
| D.   | B6       | (5) H&S Decal                                     |                 |        |
| E.   | 2700B    | (2) Warning - Stay Clear of Rake                  |                 |        |
| F.   |          | Serial Number                                     |                 |        |
| G.   | 11599    | Warning - Do Not Go Near Leaks                    |                 |        |
| H.   | 72203A   | Warning - Help Avoid Injury                       |                 |        |
| I.   | H&S      | Patent numbers                                    |                 |        |
| J.   | 73100A   | Locking Pin Storage                               |                 |        |
| K.   | 73100B   | Install Locking Pins                              |                 |        |
| L.   | 73100C   | Install Locking Pin                               |                 |        |
| M.   | 22500A   | (3) V-8   | Paint - H&S Red |        |
| N.   | 22500B   | (3) V-10  | ZX21            | Gallon |
| O.   | 2250C    | (3) V-12  | ZX22            | Quart  |
|      | 122203   | Complete Set of Decals                            | ZX23            | Pint   |

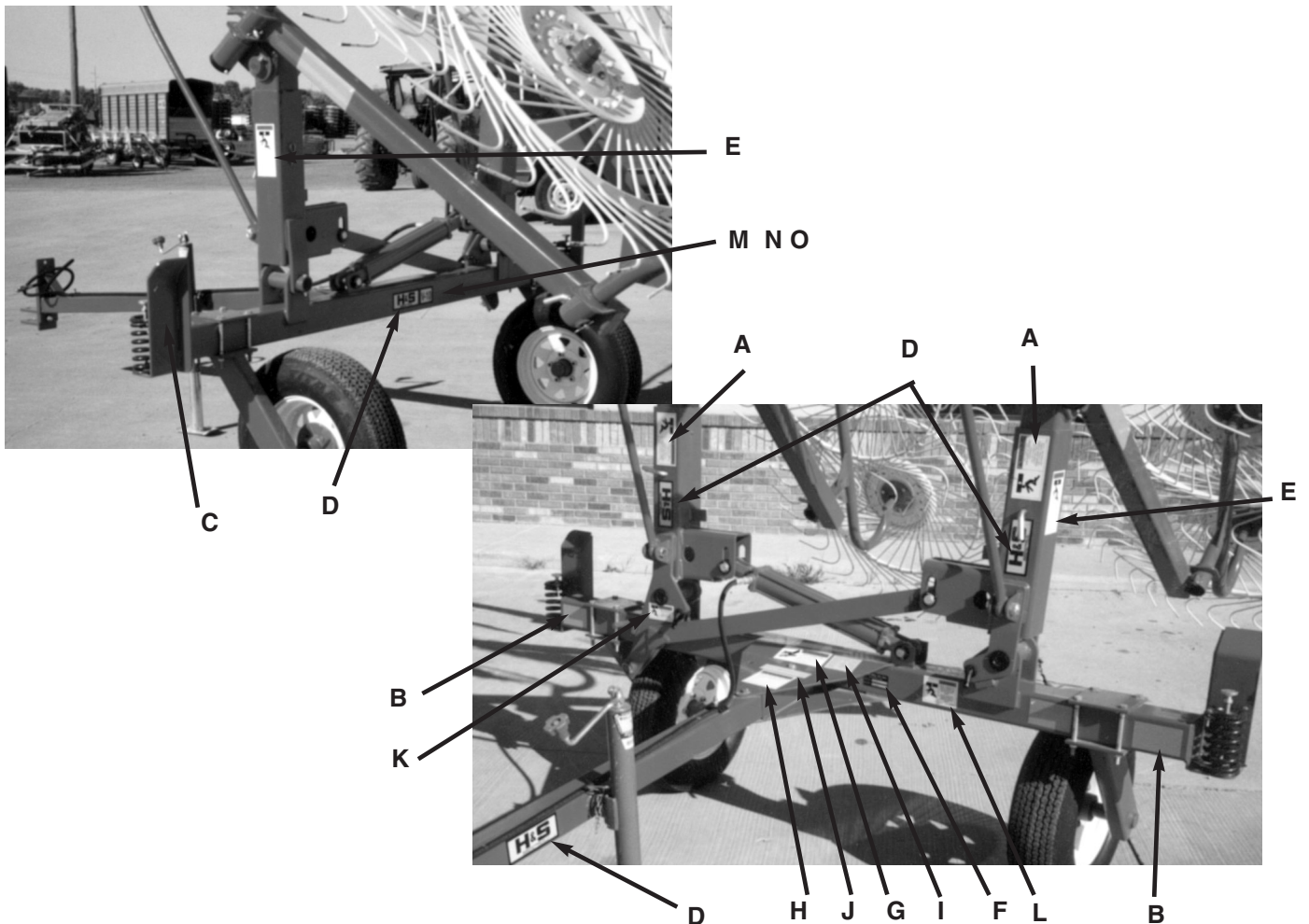

# INSTRUCTIONS FOR ORDERING PARTS

All service parts should be ordered through your authorized H&S dealer. He will be able to give you faster service if you will provide him with the following:

1. Model & Serial Number - Both are located on the left front of the main frame of your unit
2. All reference to left or right apply to the machine as viewed from the rear.
3. Parts should not be ordered from illustration only. Please order by complete part number.
4. If your dealer has to order parts - give shipping instructions:

VIA truck - large pieces (please specify local truck lines)

VIA United Parcel Service (include full address)

|                   |                      |
|-------------------|----------------------|
| H&S MFG. CO. INC. |                      |
| MARSHFIELD, WIS.  |                      |
| MOD. NO.          | <input type="text"/> |
| SER. NO.          | <input type="text"/> |
| DESCR.            | <input type="text"/> |

PLEASE RECORD NUMBERS FOR YOUR UNIT FOR QUICK REFERENCE

## ABOUT IMPROVEMENTS

H&S IS CONTINUALLY STRIVING TO IMPROVE ITS' PRODUCTS.

We must therefore, reserve the right to make improvements or changes whenever it becomes practical to do so, without incurring any obligation to make changes or additions to the equipment previously sold.



FIGURE 1

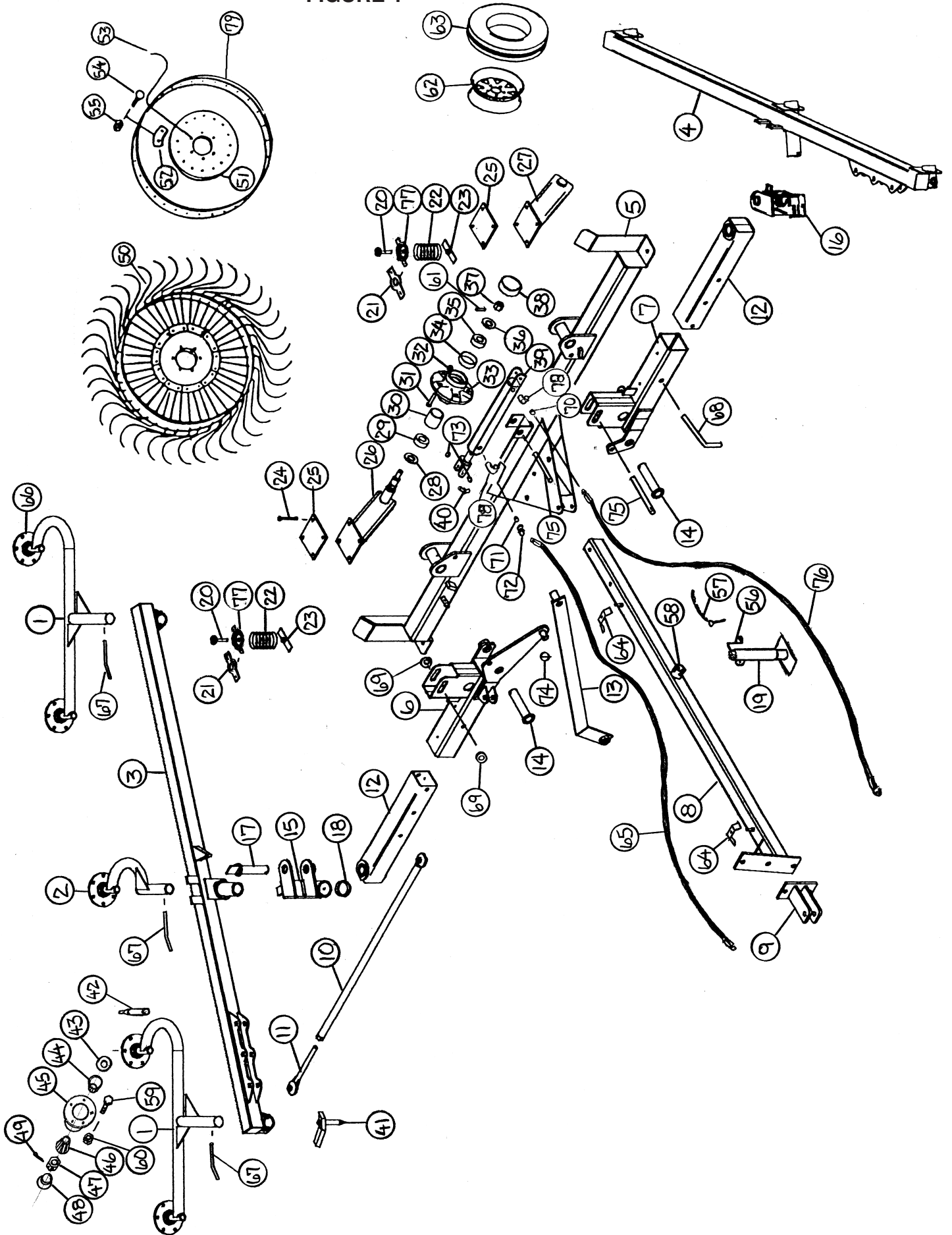

**FIGURE 1  
H&S V-RAKES**

| ITEM | PART NUMBERS / RAKE SIZE |        |        | DESCRIPTION            |
|------|--------------------------|--------|--------|------------------------|
|      | 8WR                      | 10WR   | 12WR   |                        |
| 1.   | 10WR22                   | "      | "      | Rake Arm               |
| 2.   | —                        | 10WR23 | —      | Single Rake Arm        |
| 3.   | 8WR1                     | 10WR24 | 12WR2  | Right Rake Beam        |
| 4.   | 8WR2                     | 10WR25 | 12WR3  | Left Rake Beam         |
| 5.   | 8WR9                     | 10WR26 | 12WR4  | Main Frame             |
| 6.   | 8WR7                     | 10WR27 | "      | Right Lifter Arm       |
| 7.   | 8WR6                     | 10WR28 | "      | Left Pivot Arm Housing |
| 8.   | 10WR29                   | "      | "      | Pole                   |
| 9.   | 10WR30                   | "      | "      | Hitch                  |
| 10.  | 8WR8                     | 10WR31 | "      | Link Rod               |
| 11.  | 10WR9                    | "      | "      | Adjusting Rod          |
| 12.  | 8WR5                     | 10WR34 | "      | Slide Arm              |
| 13.  | 10WR35                   | "      | 12WR5  | Lifting Linkage        |
| 14.  | 10WR7                    | "      | "      | Rake Arm Pins          |
| 15.  | 10WR36                   | "      | "      | Right Pivot Bracket    |
| 16.  | 10WR37                   | "      | "      | Left Pivot Bracket     |
| 17.  | 10WR6                    | "      | "      | Rake Beam Pin          |
| 18.  | 10WR8                    | "      | "      | Pivot Thrust Washer    |
| 19.  | BFR223                   | "      | "      | Jack                   |
| 20.  | 10WR16                   | "      | "      | Spring Adjustment      |
| 21.  | 10WR46                   | "      | "      | Spring Bottom          |
| 22.  | 10WR47                   | "      | 12WR1  | Spring                 |
| 23.  | 10WR3                    | "      | "      | Spring Clamp           |
| 24.  | 16SV77                   | "      | "      | Bolt 1/2" x 6" GR.5    |
| 25.  | —                        | —      | 10WR38 | Axle Plate             |
| 26.  | 10WR32                   | "      | "      | Right Axle             |
| 27.  | 10WR33                   | "      | "      | Left Axle              |
| 28.  | CAT5                     | "      | "      | Seal                   |
| 29.  | CAT6                     | "      | "      | Inner Bearing          |
| 30.  | CAT7                     | "      | "      | Inner Race             |
| 31.  | CAT128A                  | "      | "      | Hub Stud               |
| 32.  | CAT14                    | "      | "      | Hub Nut                |
| 33.  | 10WR49                   | "      | "      | Ground Wheel Hub       |
| 34.  | CAT9                     | "      | "      | Outer Race             |
| 35.  | CAT10                    | "      | "      | Outer Bearing          |
| 36.  | BFR63                    | "      | "      | Washer                 |
| 37.  | T35                      | "      | "      | Nut                    |
| 38.  | CAT13                    | "      | "      | Hub Cap                |
| 39.  | 10WR11A                  | "      | "      | Cylinder 2-1/2" x 16"  |
| 40.  | 10WR4                    | "      | "      | Transport Pins         |
| 41.  | 10WR5                    | "      | "      | Slide Lock Pin         |
| 42.  | BFR36                    | "      | "      | Spindle                |
| 43.  | T163                     | "      | "      | Seal                   |

FIGURE 1

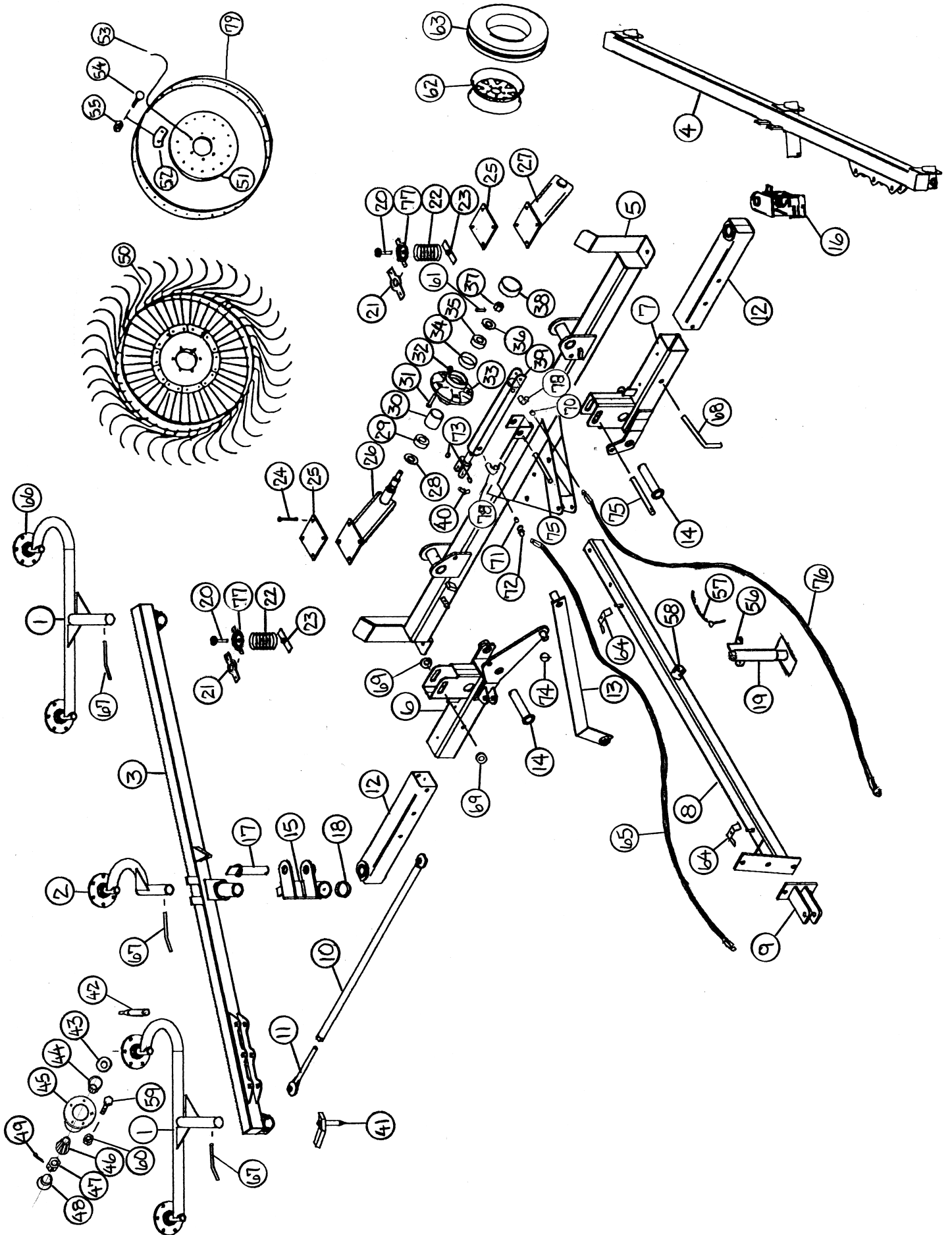

**FIGURE 1  
H&S V-RAKES**

| ITEM                                    | PART NUMBERS / RAKE SIZE |      |        | DESCRIPTION               |
|---|--------------------------|------|--------|---------------------------|
|   | 8WR                      | 10WR | 12WR   |                           |
| 44.                                     | T164                     | "    | "      | Inner Bearing             |
| *                                       | T165                     | "    | "      | Inner Race                |
| 45.                                     | BFR32                    | "    | "      | Rake Wheel Hub            |
| 46.                                     | T170                     | "    | "      | Outer Bearing             |
| *                                       | T171                     | "    | "      | Outer Race                |
| 47.                                     | T172                     | "    | "      | Nut                       |
| 48.                                     | T173                     | "    | "      | Hub Cap                   |
| 49.                                     | T169                     | "    | "      | Cotter Pin                |
| 50.                                     | BFR31                    | "    | "      | RH Rake Wheel             |
| *                                       | T174                     | "    | "      | LH Rake Wheel             |
| 51.                                     | T179                     | "    | "      | Rake Wheel Center         |
| 52.                                     | T178                     | "    | "      | Rake Tooth Clip           |
| 53.                                     | T176                     | "    | "      | Rake Wheel Tooth          |
| 54.                                     | T175                     | "    | "      | 10MM x 25MM Carriage Bolt |
| 55.                                     | T166                     | "    | "      | 10MM Nut                  |
| 56.                                     | BFR3                     | "    | "      | Jack Handle               |
| 57.                                     | BFR4                     | "    | "      | Jack Pin & Chain          |
| 58.                                     | 12N14                    | "    | "      | Jack Mount                |
| 59.                                     | T168                     | "    | "      | 10MM x 25MM Bolt          |
| 60.                                     | T166                     | "    | "      | 10MM Nut                  |
| 61.                                     | T37                      | "    | "      | Cotter Pin                |
| 62.                                     | CAT195                   | "    | "      | Wheel 13 x 4.5            |
| 63.                                     | CAT198                   | "    | "      | Tire ST175 x 80D13        |
| 64.                                     | 23N67                    | "    | "      | Hose Holder               |
| 65.                                     | 10WR10                   | "    | "      | Hose 3/8" x 145"          |
| 66.                                     | BFR76                    | "    | "      | Hub - Complete            |
| 67.                                     | 10WR13                   | "    | "      | Pin 3"                    |
| 68.                                     | 10WR14                   | "    | "      | Pin 5"                    |
| 69.                                     | 16SV136                  | "    | "      | Washer                    |
| 70.                                     | BFR70                    | "    | "      | Vent Plug                 |
| 71.                                     | BFR120                   | "    | "      | Orifice                   |
| 72.                                     | BFR122                   | "    | "      | Male Adapter Union        |
| *                                       | BFR617                   | "    | "      | Adapter Union & Orifice   |
| 73.                                     | BFR33                    | "    | "      | Washer                    |
| 74.                                     | F56                      | "    | "      | Lynch Pin                 |
| 75.                                     | LW55                     | "    | "      | Pin                       |
| 77.                                     | 10WR15                   | "    | "      | Spring Holder             |
| <b>OPTIONAL DOUBLE ACTING CYLINDER:</b> |                          |      |        |                           |
| 76.                                     | 10WR10                   | "    | "      | Hose 3/8" X 145"          |
| 78.                                     | —                        | —    | 23N234 | 90° Street Elbow          |
| 79.                                     | T177                     | "    | "      | Outer Ring                |

**NOTE:** #70 Vent Plug Not Used on Double Acting Cylinder

**NOTE:** \* (Means Not Shown)

— (Means Not Used on This Model)

" (Means Same Part No. as Preceding Model)

FIGURE 2

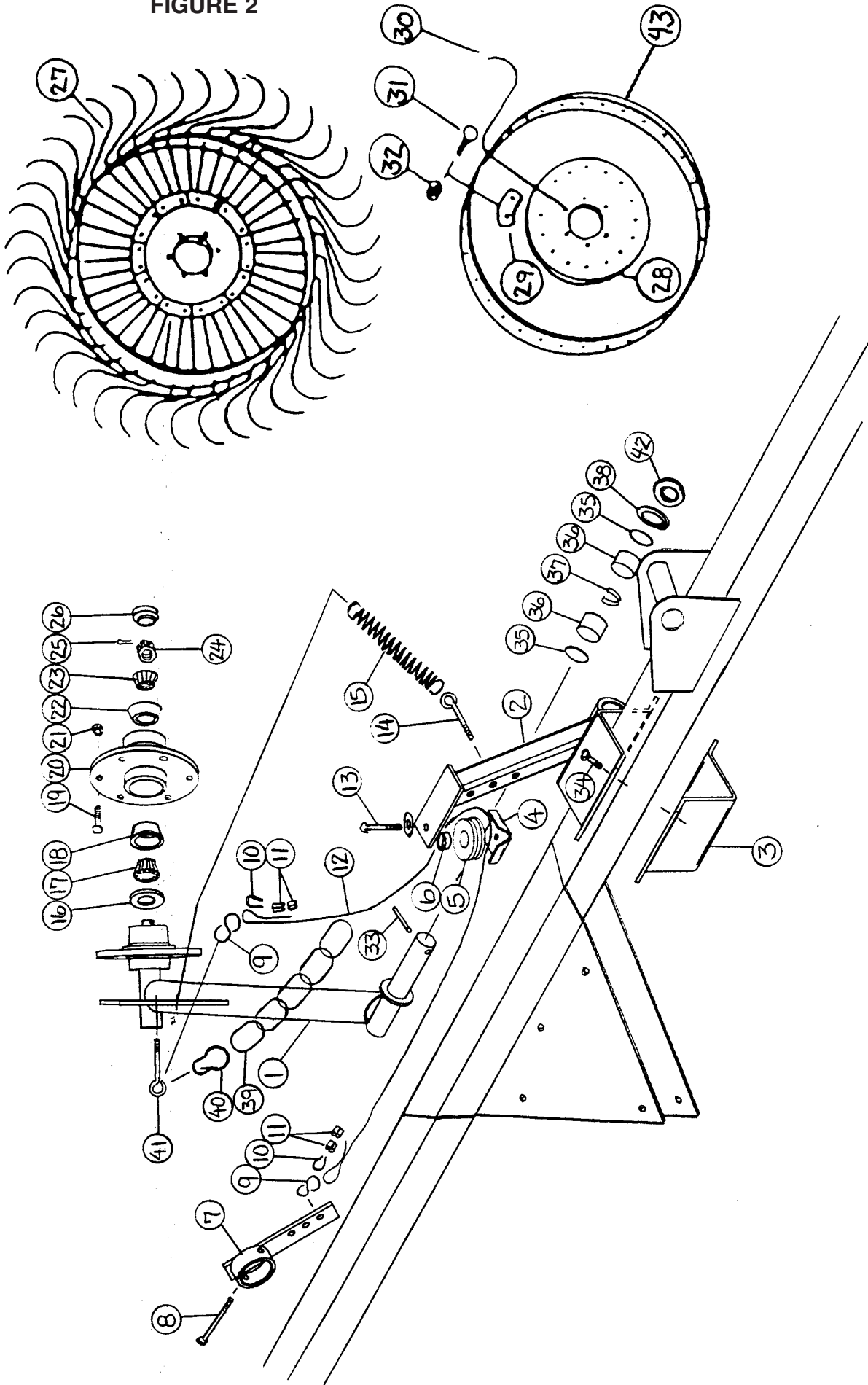
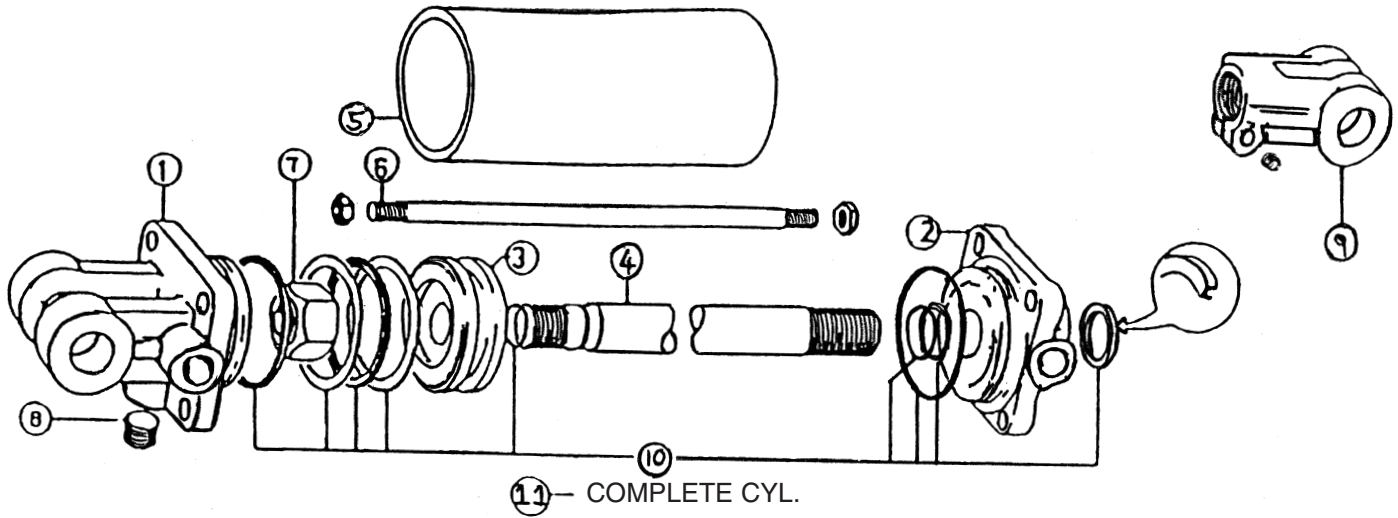



**FIGURE 2  
H&S V-RAKES  
OPTIONAL KICKER WHEEL**

| <b>ITEM</b> | <b>10WR</b> | <b>12WR</b> | <b>DESCRIPTION</b>          |
|-------------|-------------|-------------|-----------------------------|
| 1.          | 10WR41      | "           | Kicker Arm                  |
| 2.          | 10WR39      | "           | Mounting Bracket Top        |
| 3.          | 10WR20      | "           | Mount                       |
| 4.          | 10WR19      | "           | Pulley Mount                |
| 5.          | BFR292      | "           | Poly Pulley                 |
| 6.          | ST81        | "           | Spacer                      |
| 7.          | 10WR40      | "           | Pivot Mount                 |
| 8.          | 10WR18      | "           | Bolt 5/16" x 3" GR.5        |
| 9.          | F87         | "           | "S" Hook                    |
| 10.         | ES14        | "           | Cable Protector             |
| 11.         | ES5         | "           | Crimp On Clamp              |
| 12.         | 12WR6       | "           | Cable (57")                 |
| 13.         | T19         | "           | Bolt 3/8" x 2" GR.5         |
| 14.         | ES10        | "           | I-Bolt (5/16" x 4" Overall) |
| 15.         | BFR110      | "           | Spring                      |
| 16.         | T163        | "           | Seal                        |
| 17.         | T164        | "           | Inner Bearing               |
| 18.         | T165        | "           | Inner Race                  |
| 19.         | T168        | "           | Hub Bolt                    |
| 20.         | BFR32       | "           | Hub                         |
| 21.         | T166        | "           | Hub Nut                     |
| 22.         | T171        | "           | Outer Race                  |
| 23.         | T170        | "           | Outer Bearing               |
| 24.         | T172        | "           | Nut                         |
| 25.         | T169        | "           | Cotter Pin                  |
| 26.         | T173        | "           | Hub Cap                     |
| 27.         | 10WR17      | "           | 48" Kicker Wheel            |
| 28.         | T179        | "           | Rake Wheel Center           |
| 29.         | T178        | "           | Rake Tooth Clip             |
| 30.         | 10WR42      | "           | Rake Wheel Tooth            |
| 31.         | T168        | "           | Bolt 10MM x 25MM            |
| 32.         | T166        | "           | 10MM Lock Nut               |
| 33.         | 3G22        | "           | Roll Pin                    |
| 34.         | 12V45       | "           | Bolt 1/2" x 1-1/2" GR.5     |
| 35.         | S99         | "           | "O" Ring                    |
| 36.         | G16         | "           | Bronze Bushing              |
| 37.         | BFR230      | "           | Bearing Spacer              |
| 38.         | BFR221      | "           | Poly Washer                 |
| 39.         | 10WR44      | "           | Chain - 5 Links             |
| 40.         | BFR295      | "           | Snap Hook                   |
| 41.         | 10WR43      | "           | 3/8" x 1" I-Bolt            |
| 42.         | BFR229      | "           | Washer                      |
| 43.         | T177        | "           | Outer Ring                  |

**NOTE** " (Means Same Part No. as Preceding Model)



**FIGURE 3  
H&S V-RAKES**

| ITEM | PART NUMBERS / RAKE SIZE |      |      | DESCRIPTION                 |
|------|--------------------------|------|------|-----------------------------|
|      | 8WR                      | 10WR | 12WR |                             |
| 1.   | T181A                    | "    | "    | Clevis Cap                  |
| 2.   | T182A                    | "    | "    | Rod Cap                     |
| 3.   | T183                     | "    | "    | Piston                      |
| 4.   | 23N145A                  | "    | "    | Rod                         |
| 5.   | 10WR45                   | "    | "    | Cylinder Tube               |
| 6.   | 23N147                   | "    | "    | Tie Rod                     |
| 7.   | 23N148                   | "    | "    | Piston Nut                  |
| 8.   | 23N149                   | "    | "    | Plug                        |
| 9.   | 23N150A                  | "    | "    | Rod Clevis                  |
| 10.  | T187                     | "    | "    | Seal Kit                    |
| 11.  | 10WR11A                  | "    | "    | Complete Hydraulic Cylinder |

**NOTE:** " (Means Same Part No. as Preceding Model)

## H&S V-RAKES

Your new H&S V-Rake has been manufactured of the finest quality materials and components. The performance you get from your machine is largely dependent upon how well you read and understand this manual and apply this knowledge. There is a right and a wrong way to do everything. Please do not assume that you know how to operate and maintain your V-Rake before reading this manual carefully. Keep this manual available for ready reference.

### H&S V-RAKE SPECIFICATIONS

|                            | H&S V-8           | H&S V-10         | H&S V-12          |
|----------------------------|-------------------|------------------|-------------------|
| Wheel Diameter             | .55"              | 55"              | .55"              |
| Teeth Per Wheel            | .40               | 40               | .40               |
| Tooth Diameter             | .7mm              | 7mm              | .7mm              |
| Transport Width            | .9'6"             | 9'6"             | .10'6"            |
| Transport Length           | .13'              | 15'6"            | .18'              |
| Windrow Width Adjustment   | .4'-6'            | 4'-6'            | .4'-6'            |
| Raking Width               | .16'-20'          | 18'-22'          | .20'-24'          |
|                            | .3 settings       | 3 settings       | .3 settings       |
| Raking Wheel Hubs          | .Tapered Bearings | Tapered Bearings | .Tapered Bearings |
| Wing Flex                  | .Limited          | Limited          | .Limited          |
| Number of Transport Wheels | .2                | 2                | .2                |
| Hitch Jack                 | .Standard         | Standard         | .Standard         |
| Center Kicker Wheel        |                   | .Optional        | Optional          |
| Number of Rake Wheels      | .8                | 10               | .12               |
| Transport Wheels           | .ST175/80D13      | ST175/80D13      | .ST175/80D13      |
| Weight                     | .1125 lbs.        | 1275 lbs.        | .1440 lbs.        |

**NOTE**

Determine right or left side of V-Rake by viewing it from the rear. If instructions or parts lists call for hardened bolts, they are identified as Grade 5 by three lines on the head.

## H&S MANUFACTURING CO. INC.

**2608 S. Hume Ave.  
P.O. Box 768 – Telephone (715) 387-3414  
FAX (715) 384-5463  
MARSHFIELD, WI 54449**



**H&S WAREHOUSE Rt. #5 and 76  
P.O. Box 1260 – Telephone (716) 736-7595  
FAX (716) 736-7596  
RIPLEY, NY 14775**

# **H&S MFG. CO.**

products approved

for the

## **FEMA**

# **SEAL OF QUALITY**

